

The Cover-Pools® Step-Saver is a manual pool cover mechanism. Most pool covers that use the Step-Saver require two people to open the cover. The Power Wheel enables one person to open larger pool covers using the Step-Saver mechanism.

Table of Contents

1.	Step-Saver® Deck Mount Pool Cover Mechanism	2
2.	Tools or Equipment	2
3.	Track Parts	3
4.	Layout the Track	4
4.1	Track layout.	
4.2	Squaring the track.	
5.	Install the Universal Track	5
5.1	Cut the excess track.	
5.2	Install the track splice.	
5.3	Install the track guides.	
5.4	Install the end cap.	
5.5	Install the track.	
6.	Install the SnapTop™ Track	6
6.1	Cut & de-burr the track.	
6.2	Install the track bottom.	
6.3	Install the splice.	
6.4	Install the end cap.	
6.5	Install the bonding lugs.	
6.6	Install the track guides.	
7.	Install the Power Wheel™	7
7.1	Install the Rocky's Eazy Rollers®.	
7.2	Install the webbing roller.	
7.3	Install the pull strap to the Power Wheel.	
7.4	Install the end rib.	
7.5	Install the rib cover to the end rib.	
7.6	Thread the strap and attach the pull handle.	
8.	Install Fabric & Leading Edge	9
8.1	Install the fabric to the leading edge.	
8.2	Install the wheel assembly.	
8.3	Attach the pull cords.	
8.4	Attach the fabric to the roller tube.	
9.	Safety Requirements for A.S.T.M. Compliance	12
9.1	Install safety strap.	
9.2	Install the deck anchor.	
9.3	Install the roller opening barricade.	
10.	Optional Bonding.....	14
10.1	Connect the bonding lug to the leading edge.	
10.2	Connect the bonding lug to the A-frames.	
10.3	Replace the plastic bushing with the brass bushing.	
10.4	Connect the bonding lug to the aluminum angle.	
10.5	Connect the bonding lug to the track.	

1. Step-Saver® Deck Mount Pool Cover Mechanism

To uncover the pool, pull the handle on the Power Wheel; store the strap in its storage bag. To cover the pool, lay the Power Wheel strap along the side of the track. Then, attach the pull rope(s) to the front of the leading edge and pull it evenly to the opposite end.

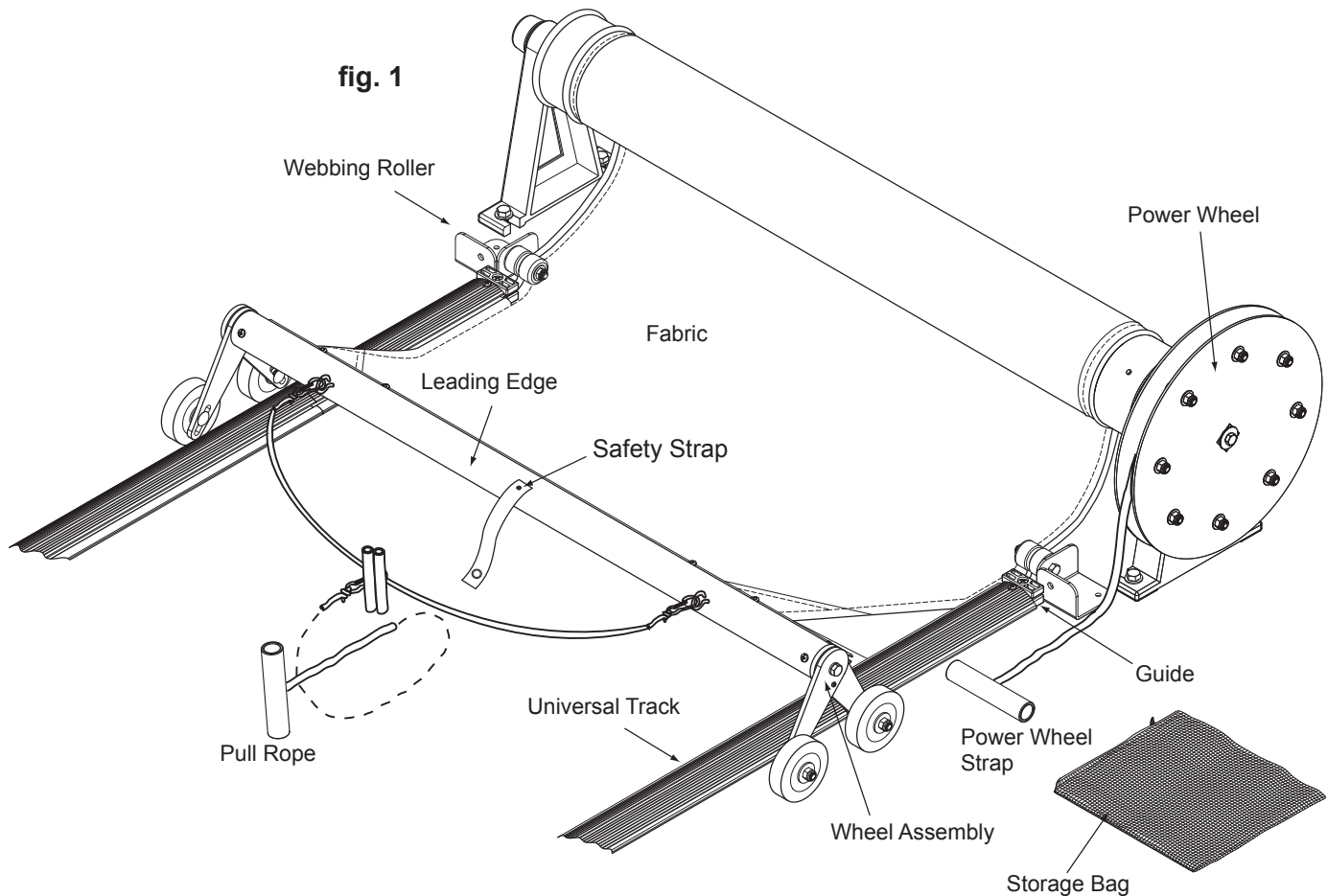

2. Tools or Equipment

- 1/2" Wrench or Socket assembly
- Measuring Tape
- Countersink (Recommend 1/2" to 5/8")
- #3 & #2 Phillips Power Bit or Driver
- 9/64" Drill Bit
- 5/32" Drill Bit
- 11/64" Drill Bit
- 7/32" Drill Bit
- 1/4" Masonry Drill Bit
- 5/16" Drill Bit
- 5/8" Masonry Drill Bit
- Saw for Cutting Aluminum
- Level
- Drill
- File (Recommend 7/16" Wide x 9/64" Thick - Half-round)

3. Track Parts

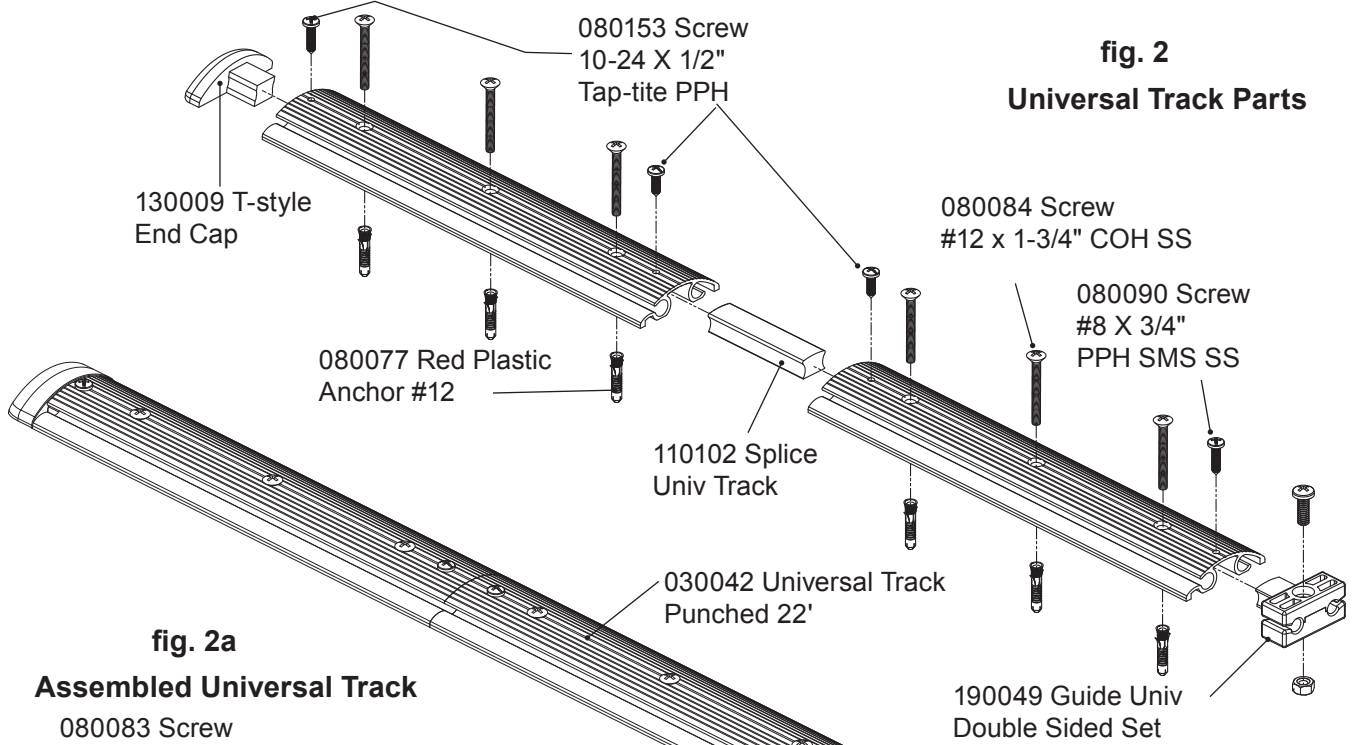

fig. 2

Universal Track Parts

fig. 2a

Assembled Universal Track

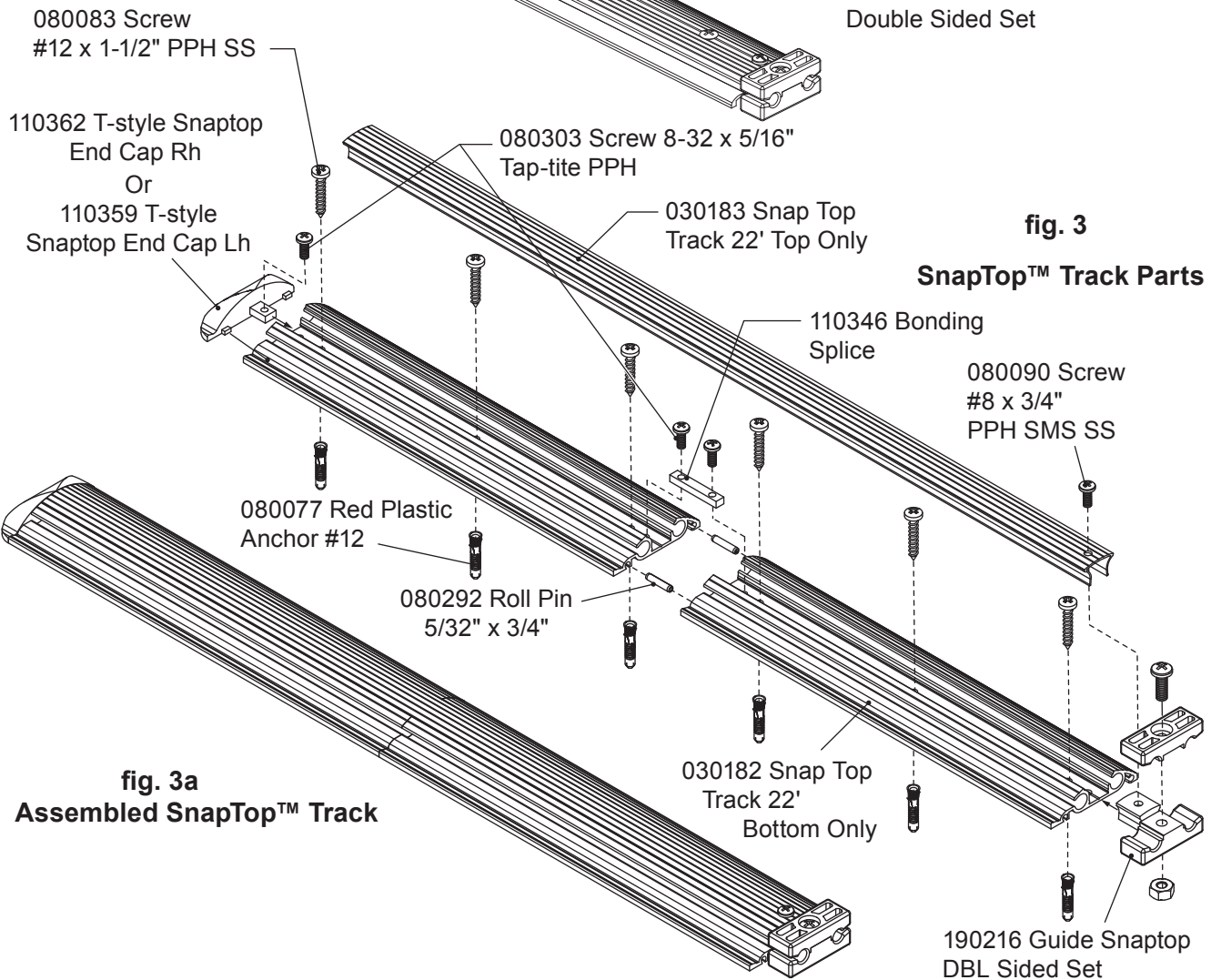

fig. 3

SnapTop™ Track Parts

fig. 3a

Assembled SnapTop™ Track

4. Lay Out the Track

4.1 Track layout. (fig. 4 & 5)

Check the specified "Track Space (T.S.)" as written on the shop order form or packing list.

The track space is the distance from the inside edge of the track to the inside edge of the track plus 1". (fig. 4)

4.1.1 Lay the tracks out at right angles to the mechanism with the track slots facing the pool.

4.1.2 Place the track ends 2' beyond the far end of pool and 1" beyond the pool on the mechanism end.

4.1.3 Cut off any excess track squarely at the mechanism end.

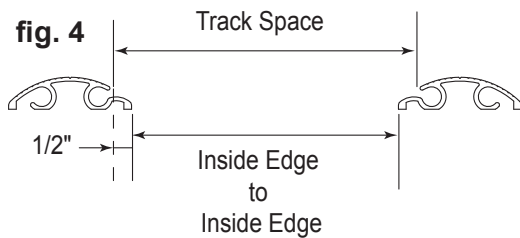
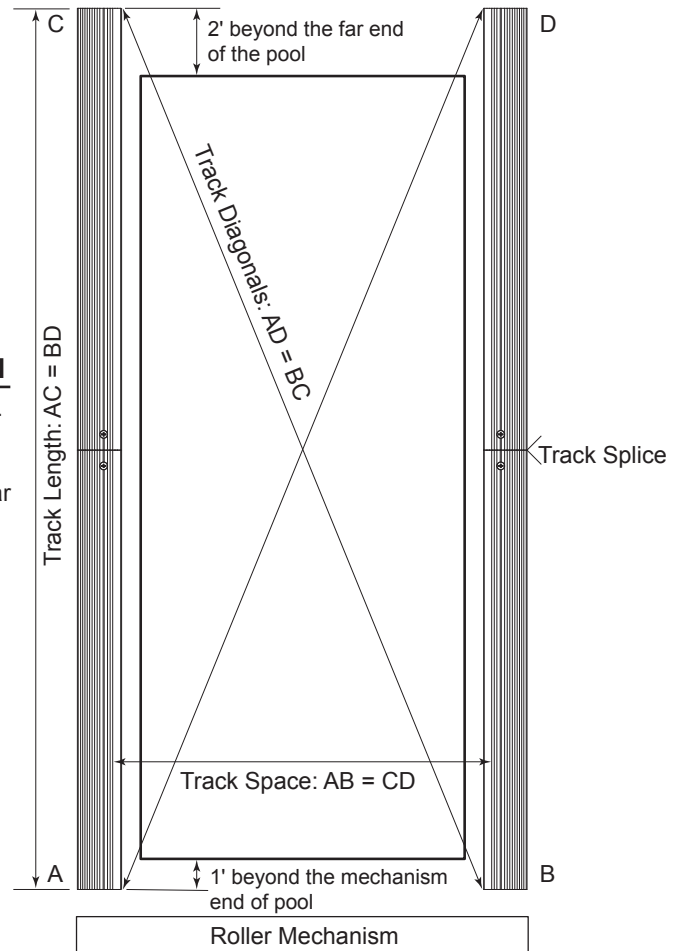

fig. 5

ATTENTION **CRITICAL INSTRUCTION**

1. Tracks must be equal length.
2. Tracks must be parallel.
3. Tracks must be squared.
4. Tracks must be perpendicular to the mechanism.



4.2 Squaring the track. (fig. 5)

Note: For SnapTop™ track, use the track bottom sections for layout. Plan for all joints between the top and bottom pieces to be offset.

- 4.2.1 Measure the track space at both ends and the middle to ensure the tracks are parallel.
- 4.2.2 Measure the diagonal to ensure a perfectly squared track layout.
- 4.2.3 Mark the track position with a pencil at the ends and several places in between.
- 4.2.4 Hold the track in position and mark the hole positions with a pencil or 1/4" masonry drill bit.
- 4.2.5 Move the tracks and drill 1/4" holes 2" deep at the marked hole locations.
- 4.2.6 Blow or vacuum the dust out of the holes.
- 4.2.7 Insert red plastic anchors into the drilled holes and tap them into place.

5. Install the Universal Track

Note: *If using SnapTop™ track, skip to the next section for proper installation procedure.*

5.1 Cut the excess track. (fig. 6 & 7)

- 5.1.1 De-burr all sharp edges from the tracks, especially the pool-side rope channel.
- 5.1.2 Use a file or countersink on all track ends to de-burr and bevel them.

5.2 Install the track splice. (fig. 7)

- 5.2.1 Use a track splice to join squarely cut track ends.
- 5.2.2 Make sure the tracks are held tightly together.
- 5.2.3 Drill a 5/32" hole through each track and into the splice.
- 5.2.4 Use #10 x 1/2" screws to fasten the splice and track together.

5.3 Install the track guides. (fig. 8)

The double sided guide consists of two halves that are installed at the mechanism end of the track.

- 5.3.1 Place both halves together and secure with the bolt and nut provided.
- 5.3.2 Insert the stem of the guide into the track. Make sure the bottom of the guide is parallel with the bottom of the track and tight against the track end.
- 5.3.3 Drill a 9/64" hole through the track and the guide.
- 5.3.4 Secure the guide in place with a #8 x 3/4" screw.

5.4 Install the end cap. (fig. 9)

The end cap is installed on the far end of the track.

- 5.4.1 Make sure the bottom of the end cap is parallel with the bottom of the track and tight against the track end.
- 5.4.2 Drill a 9/64" hole through the track and end cap.
- 5.4.3 Secure the end cap in place with a #10-24 x 1/2" tap-tite screw.

5.5 Install the track. (fig. 3)

Install the tracks and secure them to the deck surface.

- 5.5.1 Place the tracks in their original position and secure with #12 x 1 3/4" screws.

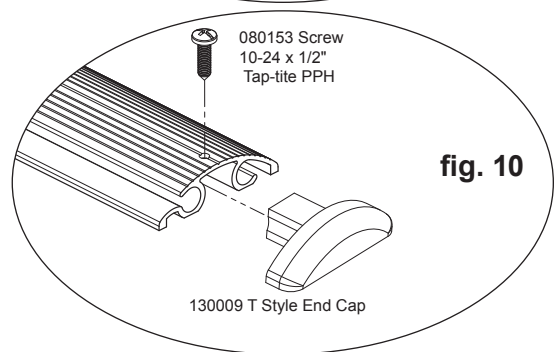
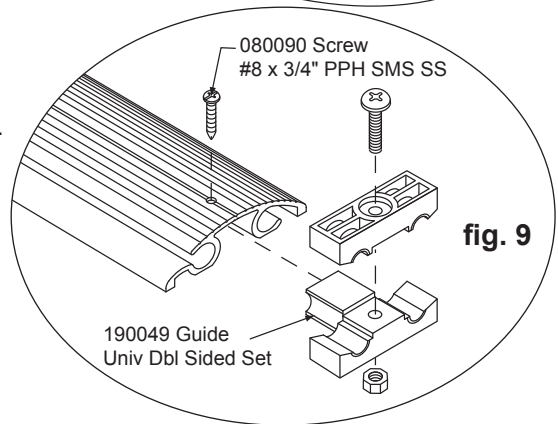
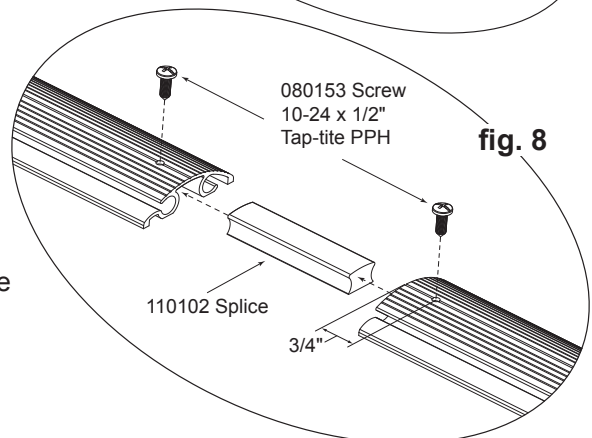
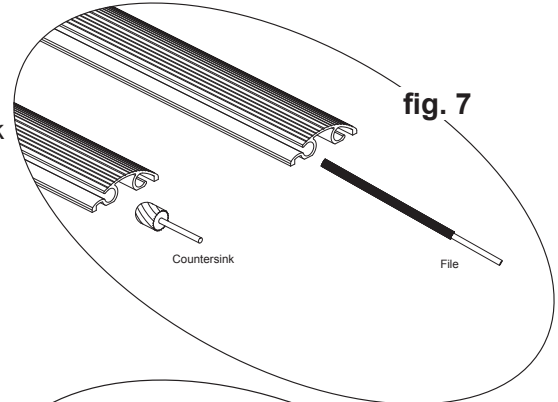
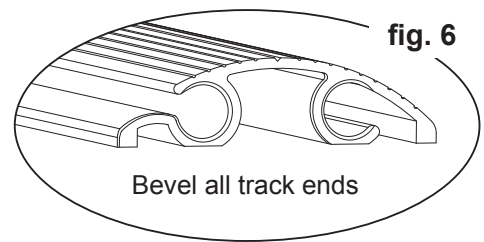

6. Install the SnapTop™ Track

Note: *If using Universal track, refer to previous section for proper installation procedure.*

6.1 Cut & de-burr the track. (fig. 11)

- 6.1.1 Use a file or countersink on all track ends to de-burr and bevel them, especially the pool-side rope channel.

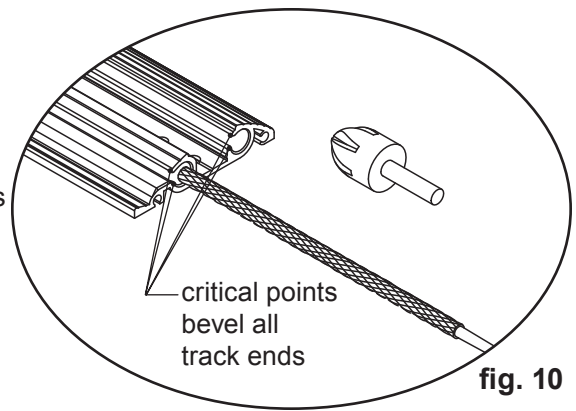

fig. 10

6.2 Install the track bottom. (fig. 11a)

- 6.2.1 Replace the track bottom to its original position. Tap two 5/32" x 3/4" roll pins into the slots in the track 3/8" deep (halfway). Press a second track bottom onto the roll pins. Attach the remaining track bottoms to each other in the same way.

- 6.2.2 Secure with two #12 x 1-1/2" screws.

6.3 Install the splice. (fig. 11a)

- 6.3.1 Install bonding splice at all track joints to ensure continuity of electrical bonding.

- 6.3.1.1 Using the bonding splice as a template, drill two 1/8" holes at the joints.

- 6.3.1.2 Attach bonding splice using two 8-32 x 5/16" tap-tite screw.

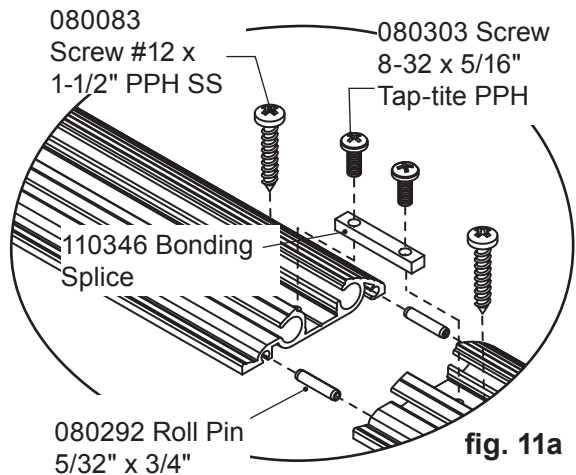

fig. 11a

6.4 Install the end cap. (fig. 11b)

- 6.5.1 Slide T-style SnapTop end cap RH or T-style SnapTop end cap LH into the bottom of the track until it is flush with the end of the track.

- 6.5.2 Drill a 1/8" hole through the end cap stem into the track bottom.

- 6.5.3 Secure with a 8-32 x 5/16" tap-tite screw.

6.5 Install the bonding lugs. (fig. 11c)

- 6.5.1 Drill an 11/64" hole through the track top at least 3/4" from the end.

- 6.5.2 Insert the screw from the inside to attach the starwasher and ground lug with the nylock nut.

- 6.5.3 Install the top into the track making sure the top and bottom joints are offset.

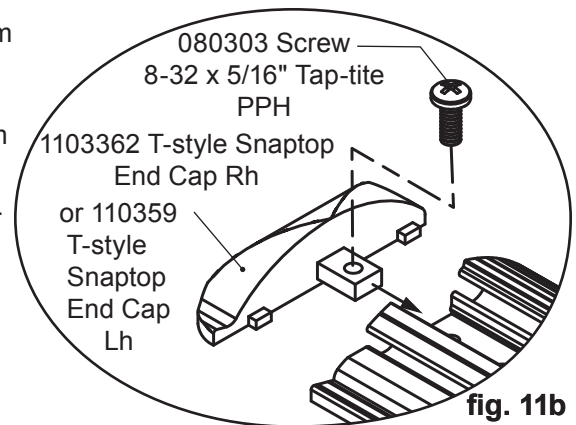

fig. 11b

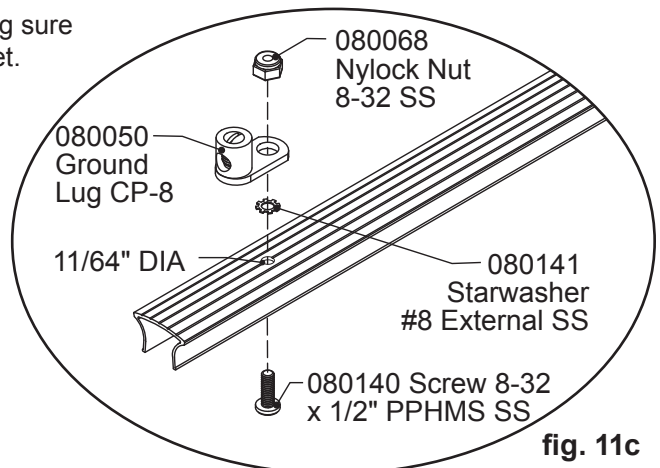

fig. 11c

6.6 Install the track guides. (fig 11d)

Note: *The track top must be in place before the guide can be installed.*

- 6.6.3 Place both halves of the rope guide together and secure them with the bolt and nut provided.
- 6.6.4 Insert the stem of the guide into the end of track flush against the track end.
- 6.6.5 Drill a 9/64" hole completely through the track and the guide assembly stem.

080090 Screw #8 x 3/4"
(19 mm) PPH SMS SS

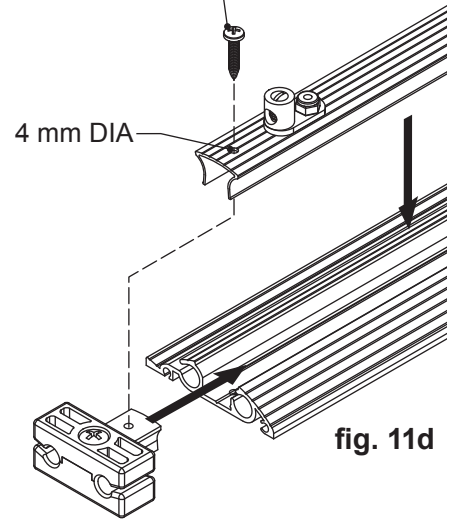

7. Assemble the Power Wheel™

7.1 Assemble the Rocky's Eazy Rollers®. (fig. 12)

- 7.1.1 Set the Rocky's Eazy Rollers A-frame 3½" from the end of the track and approximately 1¾" from the outside edge of the track.
- 7.1.2 Insert the tube into the hub.
- 7.1.3 Use the instructions in the Rocky's Eazy Rollers kit to assemble the tube and roller.
- 7.1.3 Install the Power Wheel in place of the handle with the nuts facing away from the tube and secure with the bolt.
- 7.1.4 Level and center the mechanism.

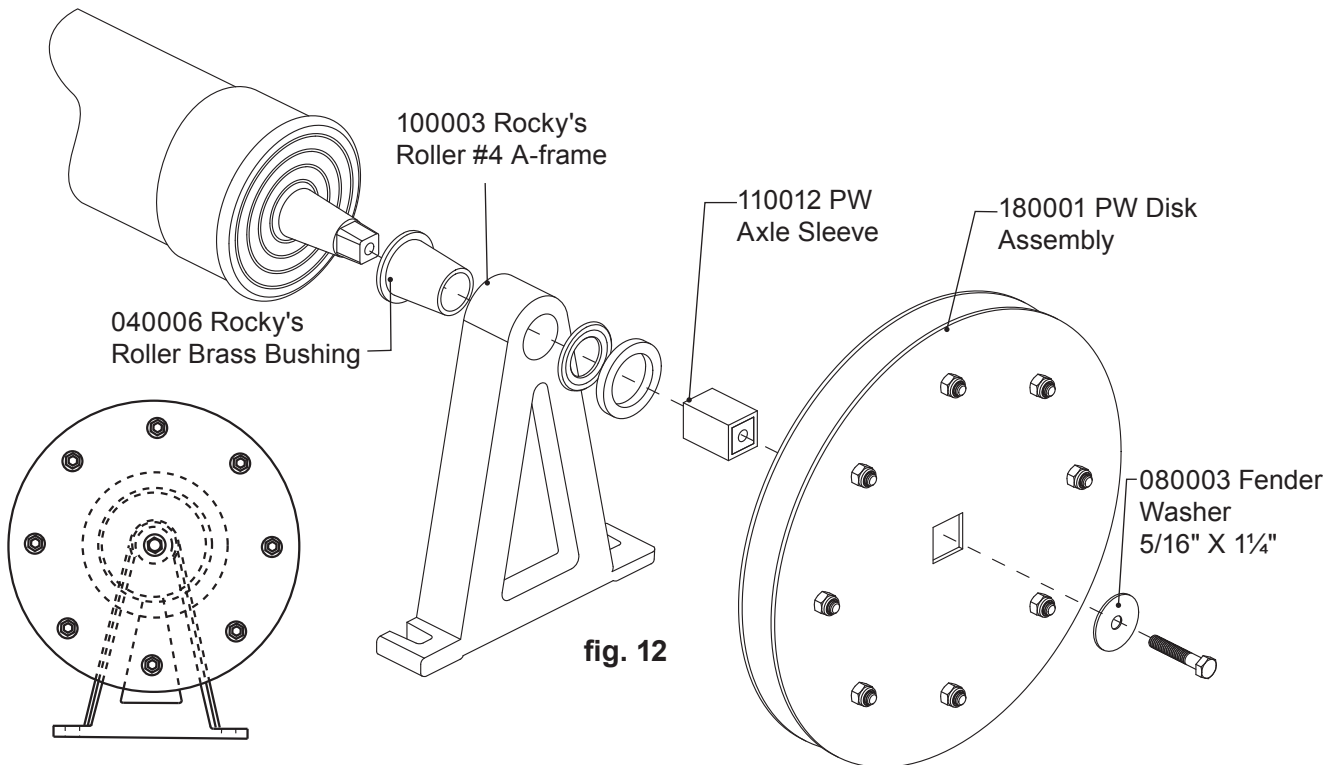

7.2 Install the webbing roller. (fig. 13)

The webbing rollers are installed at the mechanism end on both sides of the pool.

7.2.1 Set the webbing roller bracket on the deck squarely against the guide.

7.2.2 Line up the groove in the webbing roller with the guide and webbing.

7.2.3 The outside edge of the roller bracket sits about $1\frac{3}{4}$ " away from the outside edge of the track.

7.2.4 Hold the roller bracket in position and mark the hole locations with a pencil or $\frac{1}{4}$ " masonry drill.

7.2.5 Move the roller and drill the marked hole locations 2" deep with $\frac{1}{4}$ " masonry drill.

7.2.6 Blow the dust out of the holes.

7.2.7 Insert red plastic anchors into the drilled holes and tap them into place.

7.2.8 Place the webbing roller back in position and secure it with #12 x $1\frac{3}{4}$ " screws.

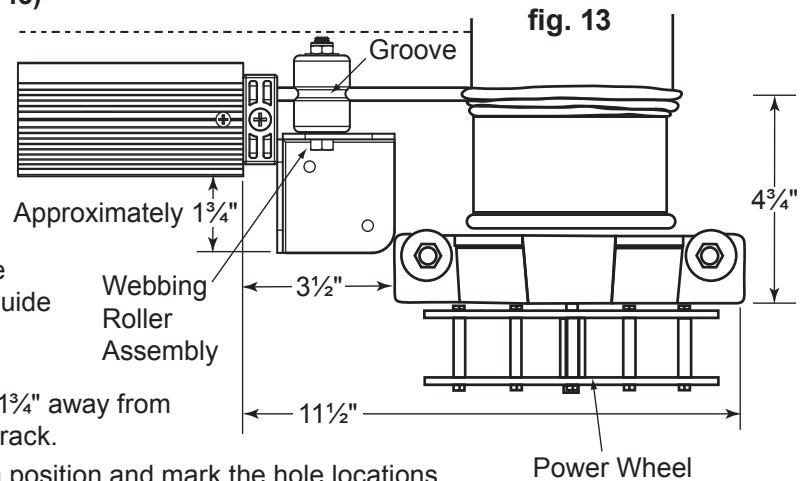

7.3 Install the pull strap to the Power Wheel. (fig. 14)

7.3.1 Remove one cross bar from the wheel. Insert the bar into the loop of the strap and reinstall the cross bar into the wheel.

7.3.2 The pull strap feeds from the top of the Power Wheel.

7.3.3 Hand wrap the strap around the Power Wheel. Be careful not to twist the strap.

7.3.4 Leave enough of the strap extended to thread through the rib cover and into the handle.

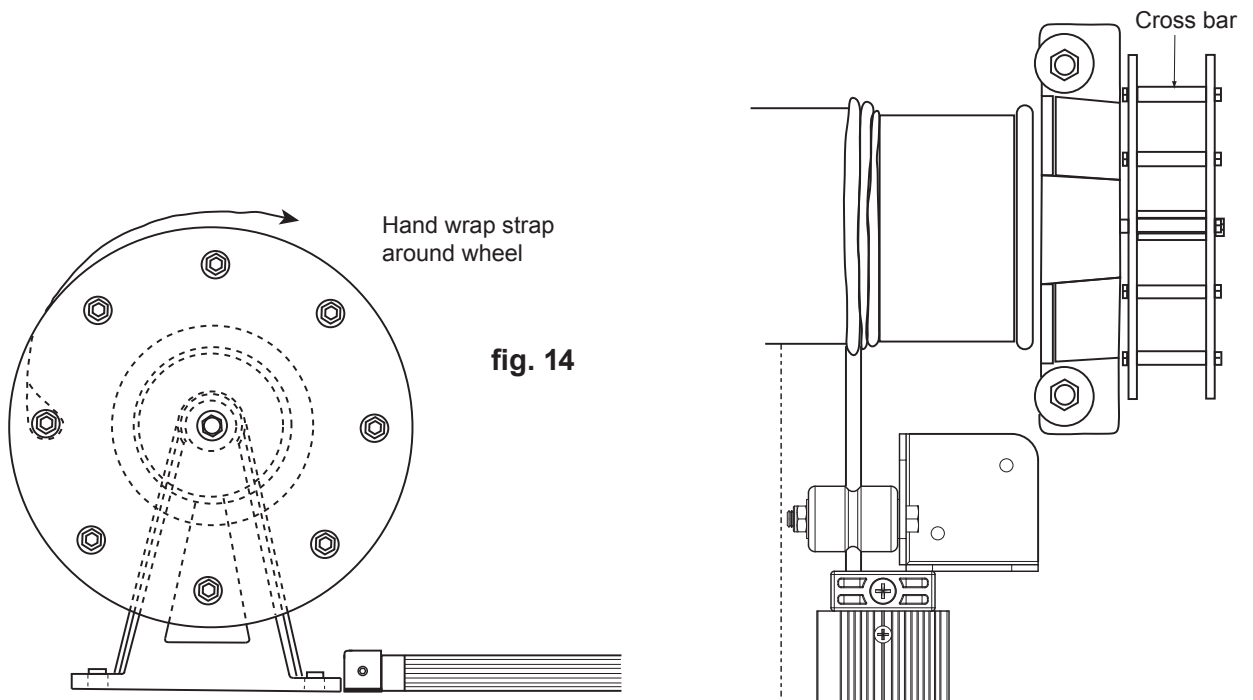

7.4 Install the end rib. (fig. 15)

- 7.4.1 Center the rib over the Power Wheel.
- 7.4.2 Holding the rib in position, mark the hole locations with a pencil or 1/4" masonry drill.
- 7.4.3 Remove the rib and drill 1/4" holes 2" deep with a masonry drill at the marked hole locations.
- 7.4.4 Blow the dust out of the holes.
- 7.4.5 Insert red plastic anchors into the drilled holes and tap them into place.
- 7.4.6 Place the rib back into position and secure it with #12 x 1 3/4" screws.

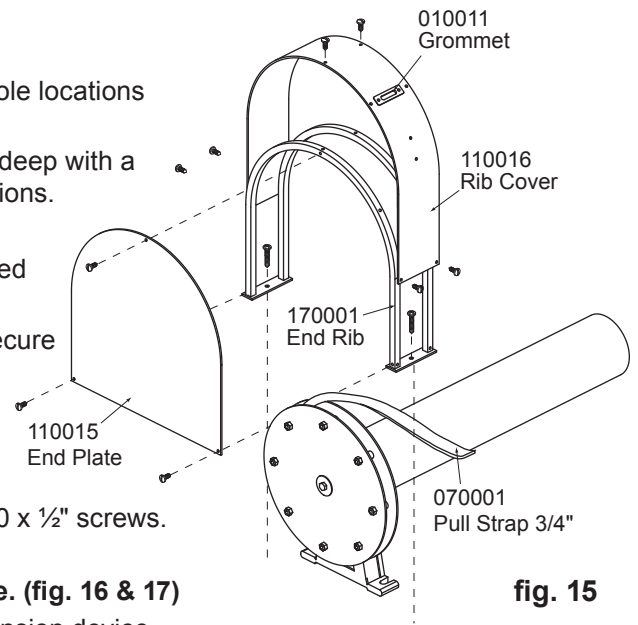

fig. 15

7.5 Install the rib cover to the end rib.

- 7.5.1 Place the rib cover over the rib facing the grommet toward the track.
- 7.5.2 Secure the rib cover to the rib with #10 x 1/2" screws.

7.6 Thread the strap and attach the pull handle. (fig. 16 & 17)

- 7.6.1 Thread the strap over the top of the tension device and through the grommet in the rib cover.
 - 7.6.1.1 Thread the strap through the small hole in the handle and out one side.
 - 7.6.1.2 Slide the handle down the strap so the handle almost touches the rib cover.
 - 7.6.1.3 Tie a knot in the strap. Cut off the excess strap and pull the knot into the handle.

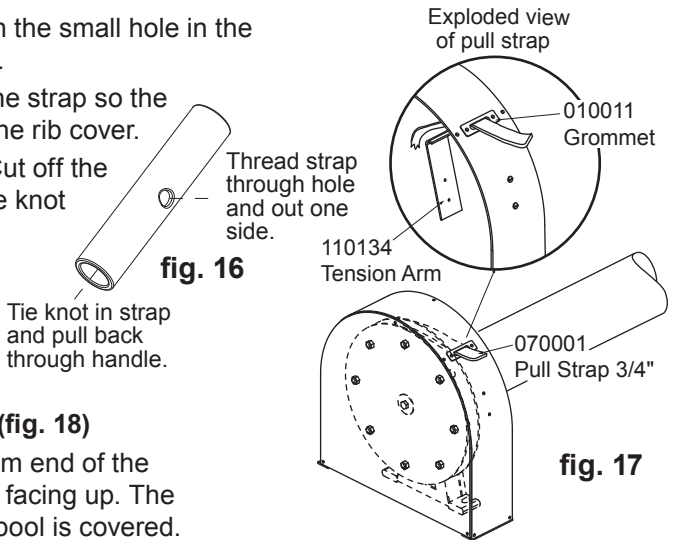

fig. 16

fig. 17

8. Install Fabric & Leading Edge

8.1 Install the fabric to the leading edge. (fig. 18)

- 8.1.1 Unroll the fabric at the mechanism end of the pool with the Cover-Pools labels facing up. The labels must be visible when the pool is covered.
- 8.1.2 On one side of the pool, insert the cover webbing through the guide and about 1' into the track.
- 8.1.3 On the opposite side, pull the corner of the fabric tight and slide the leading edge onto the front of the fabric.
- 8.1.4 Leave the Teflon gore outside of the leading edge channel and slide the leading edge across the front of the fabric to the opposite side.
- 8.1.5 Set the fabric in about 3" on both ends of the leading edge.
- 8.1.6 Evenly compress any extra fabric into leading edge channel.
- 8.1.7 Insert the opposite edge of the cover webbing through the guide and about 1' into the track.
- 8.1.8 Pin through the pre-drilled holes on both ends of leading edge into the fabric using pinning screws.

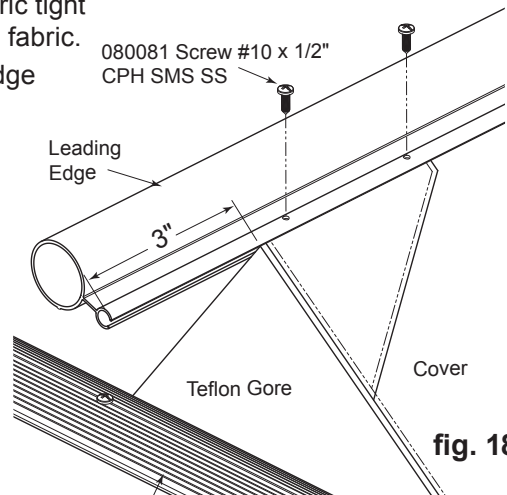

fig. 18

8.2 Install the wheel assembly. (fig. 19 & 20)

The wheel assembly is installed and attached to the leading edge.

- 8.2.1 Insert the wheel assembly plug into the leading edge. (fig. 18)
- 8.2.2 Drill a 5/32" hole through the leading edge into the plug at the 10:00 and 2:00 positions. (fig. 19)
- 8.2.3 Pin the plug to the leading edge with #10 x 1/2" screws through the drilled holes.
- 8.2.4 Loosen the wheel plug bolt to adjust the leading edge height.
- 8.2.5 Set the bottom of the leading edge approximately 2" above the track.
- 8.2.6 Tighten the wheel plug bolt until it is snug.
- 8.2.7 Drill a 7/32" hole through the two wheel arms; **do not drill into the plastic wheel hub.**
- 8.2.8 Pin the wheel arms together with a #12 x 1-1/2" Screw (080083) through the drilled holes and into the wheel hub.

fig. 19

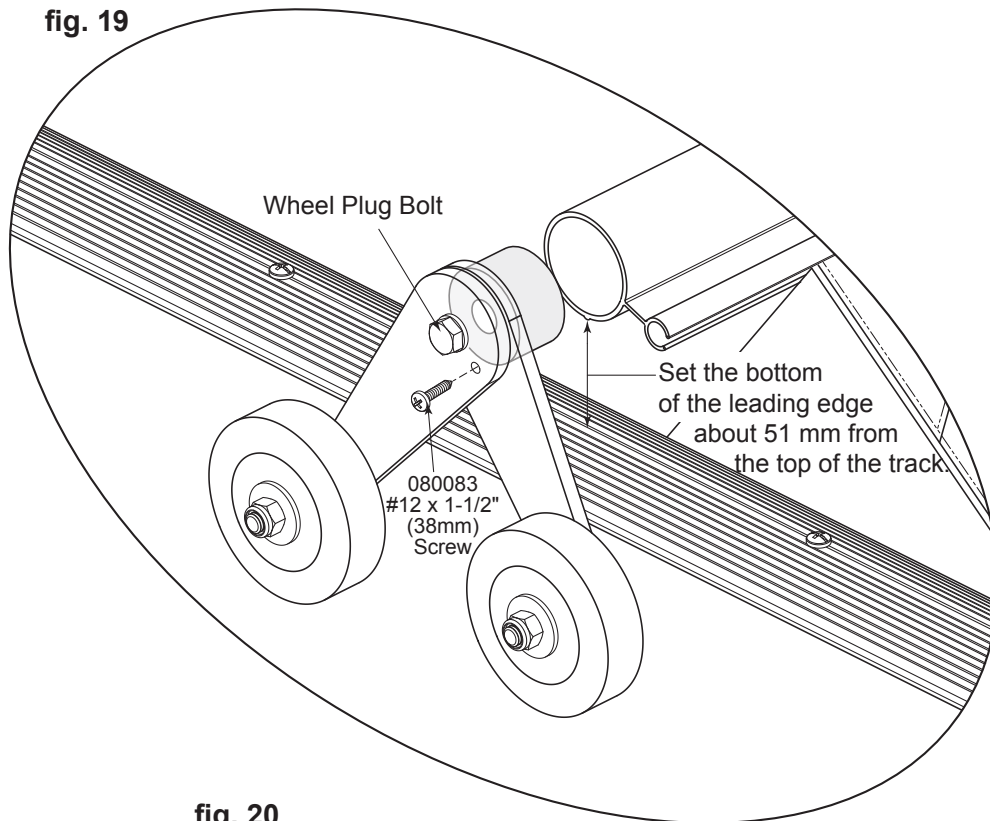
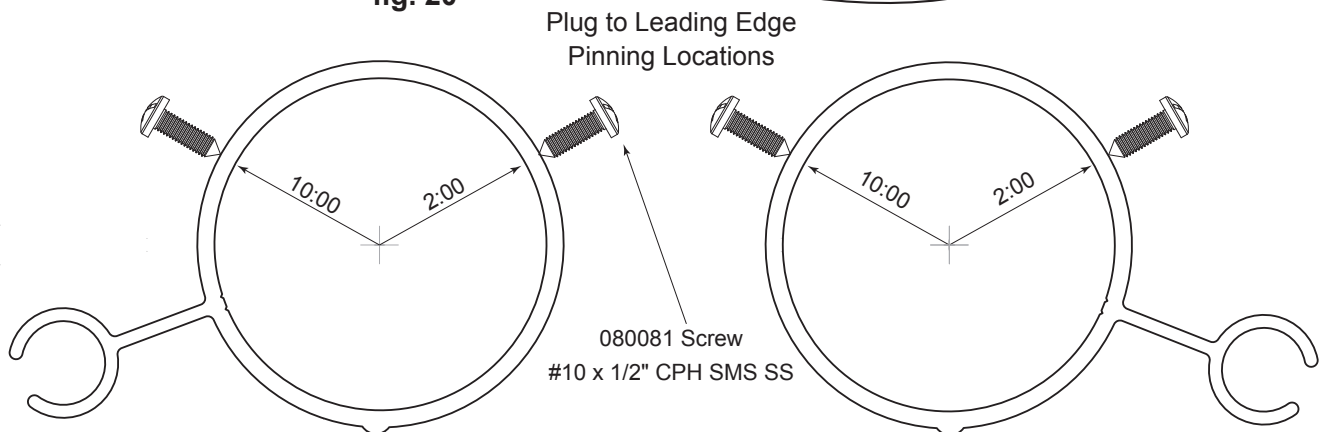

fig. 20



8.3 Attach the pull cords. (fig. 21 & 22)

The pull cords are attached to the leading edge and used to cover the pool.

8.3.1 **Two-person operation:** attach the pull cord clips to the eyelets on the leading edge.

8.3.2 **One-person operation:** attach the pull cord clips to the eyelets on the leading edge and attach the third pull cord clip to the ropes just below handles.

8.3.3 To cover the pool, pull the cords and leading edge evenly on both sides. When closing, if the leading edge advances unevenly, it will bind and be hard to pull.

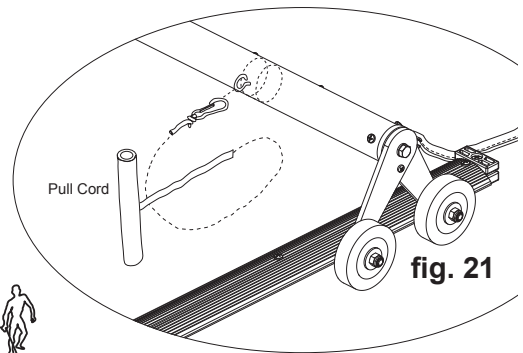

fig. 21

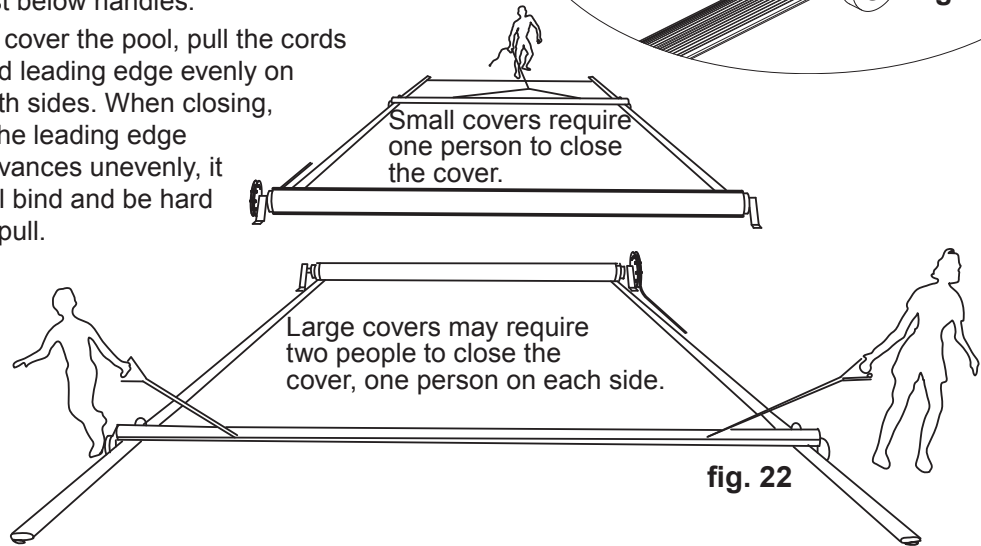

fig. 22

8.4 Attach the fabric to the roller tube. (fig. 23)

8.4.1 Pull the fabric under the tube in a straight line from the guide and webbing roller.

8.4.2 Pin with #10 x 1/2" screws.

8.4.2.1 First, pin the webbing to the pre-drilled holes on both ends of the roller tube.

8.4.2.2 Leave 1/2" of slack in the fabric and pin the fabric to the next pre-drilled hole.

8.4.2.3 Continue pinning the fabric (except the center) to the roller tube at each pre-drilled hole.

8.4.2.4 Find the center of the fabric and pin it to the roller tube.

8.4.3 As the fabric is rolled onto the roller tube, fold the extra fabric toward the center.

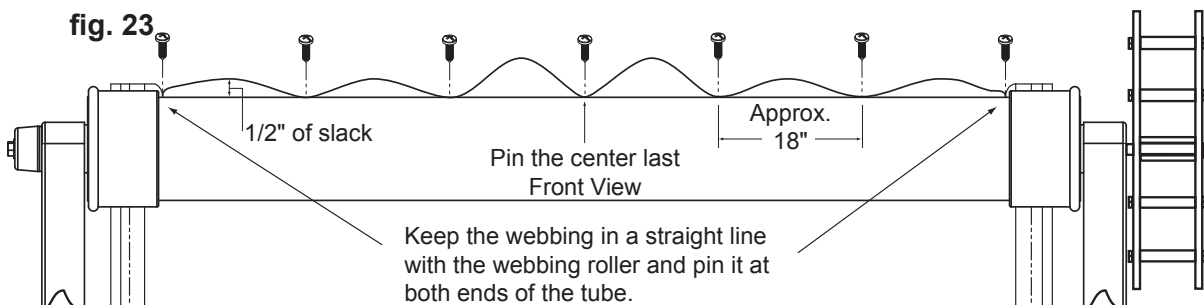
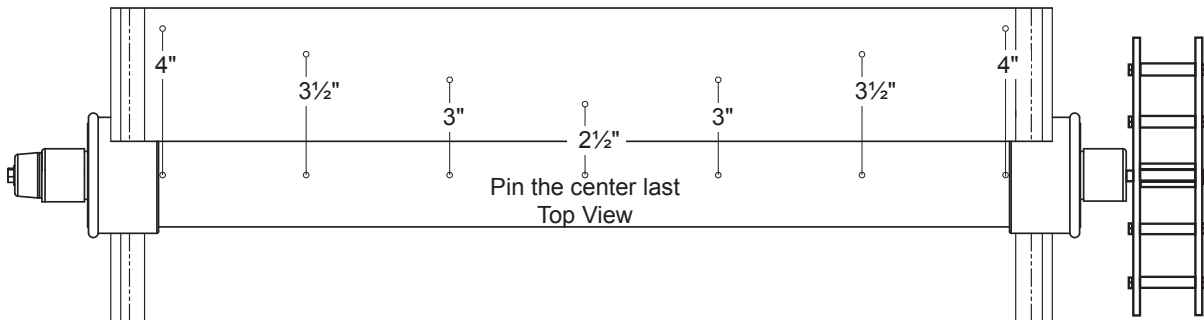

fig. 23

9. Safety Requirements for A.S.T.M. Compliance

Safety Strap: (A.S.T.M. COMPLIANCE INSTRUCTION)

The safety strap is used to prevent a force from creating an opening between the leading edge and the deck.

9.1 Install safety strap.

- 9.1.1 Use the pull cord and cover the pool. (fig. 24)
- 9.1.2 Locate the center of the leading edge and drill a 5/16" hole 3/4" above the leading edge flange.
- 9.1.3 Insert the rubber well nut into the drilled hole.
- 9.1.4 Insert a washer and screw 8-32 x 1" through one of the four small grommets in the safety strap and screw into the well nut. **DO NOT TIGHTEN AT THIS TIME.**
- 9.1.5 Pull the end of the strap up onto the deck and adjust the strap length.
 - 9.1.5.1 The large grommet must rest flush on the deck and hold the leading edge tightly in place when secured with the deck anchor.
 - 9.1.5.2 Adjust the safety strap length by choosing the proper small grommet.
 - 9.1.5.3 With the large grommet resting flush on deck, mark the deck anchor location through the grommet hole.

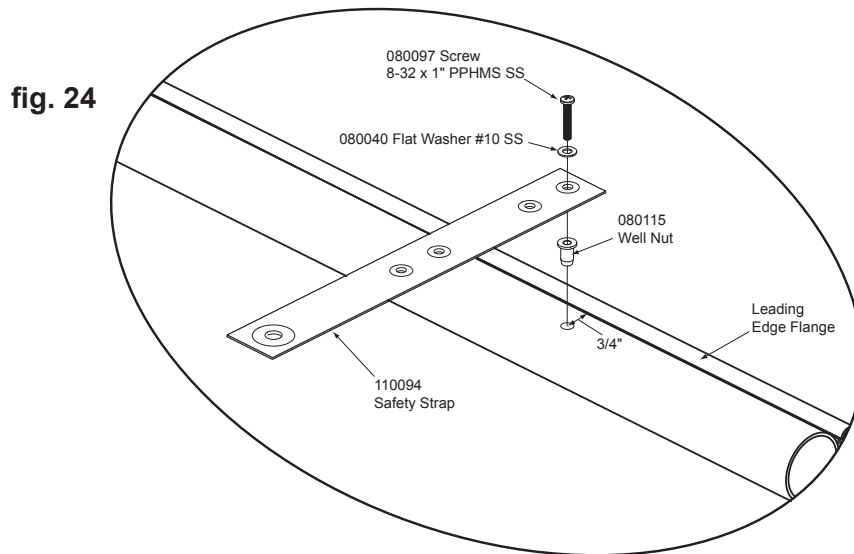

9.2 Install the deck anchor. (fig. 25)

- 9.2.1 Drill a 5/8" hole through deck at the marked location.
- 9.2.2 Push a 1" x 3/4" diameter piece of expansion foam into the drilled hole a minimum of 2" deep.
- 9.2.3 Push the housing into the hole and lightly tap it into place (**NO GLUE REQUIRED**).
- 9.2.4 Place the pin through the large grommet in the strap and push it into the deck anchor housing.
- 9.2.6 Tighten the screw in the well nut until the strap is secure.
- 9.2.7 Refer to the Owner's Manual for anchor pin removal instructions.

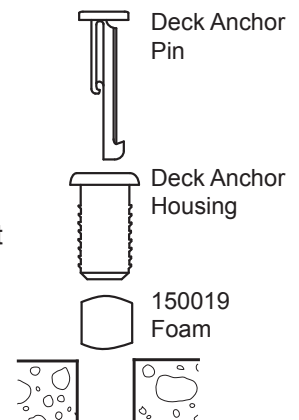

fig. 25

Roller Opening Barricade: (A.S.T.M. COMPLIANCE INSTRUCTION)

The aluminum angle is used to reduce the opening between the roller and the deck to prevent children from crawling through the closed cover. Remove the aluminum angle before the cover is opened and install the aluminum angle whenever the cover is closed. Some systems may leave the angle in place when the cover is open.

9.3 Install the roller opening barricade. (fig. 26 & 27)

- 9.3.1 Cover the pool using the pull cords.
- 9.3.2 Place the 2" x 3" aluminum angle so the 2" side is flush on the deck and 3" side faces the pool.
- 9.3.3 Align the aluminum angle parallel with the roller tube.
- 9.3.4 Adjust the aluminum angle forward or backward so the top edge is a maximum of 4" away from the outer edge of the tube. (fig. 27)
- 9.3.5 Holding the aluminum angle in position, mark the hole locations on the deck with a pencil or 1/4" masonry drill.
- 9.3.6 Remove the aluminum angle and install the deck anchors following the Deck Anchor Installation instructions.
- 9.3.7 File the top corners of the aluminum angle to de-burr and remove sharp edges and corners.
- 9.3.8 Place the aluminum angle over the installed anchor housings and insert anchor pins to secure it.
- 9.3.9 Refer to the Owner's Manual for anchor pin removal instructions.

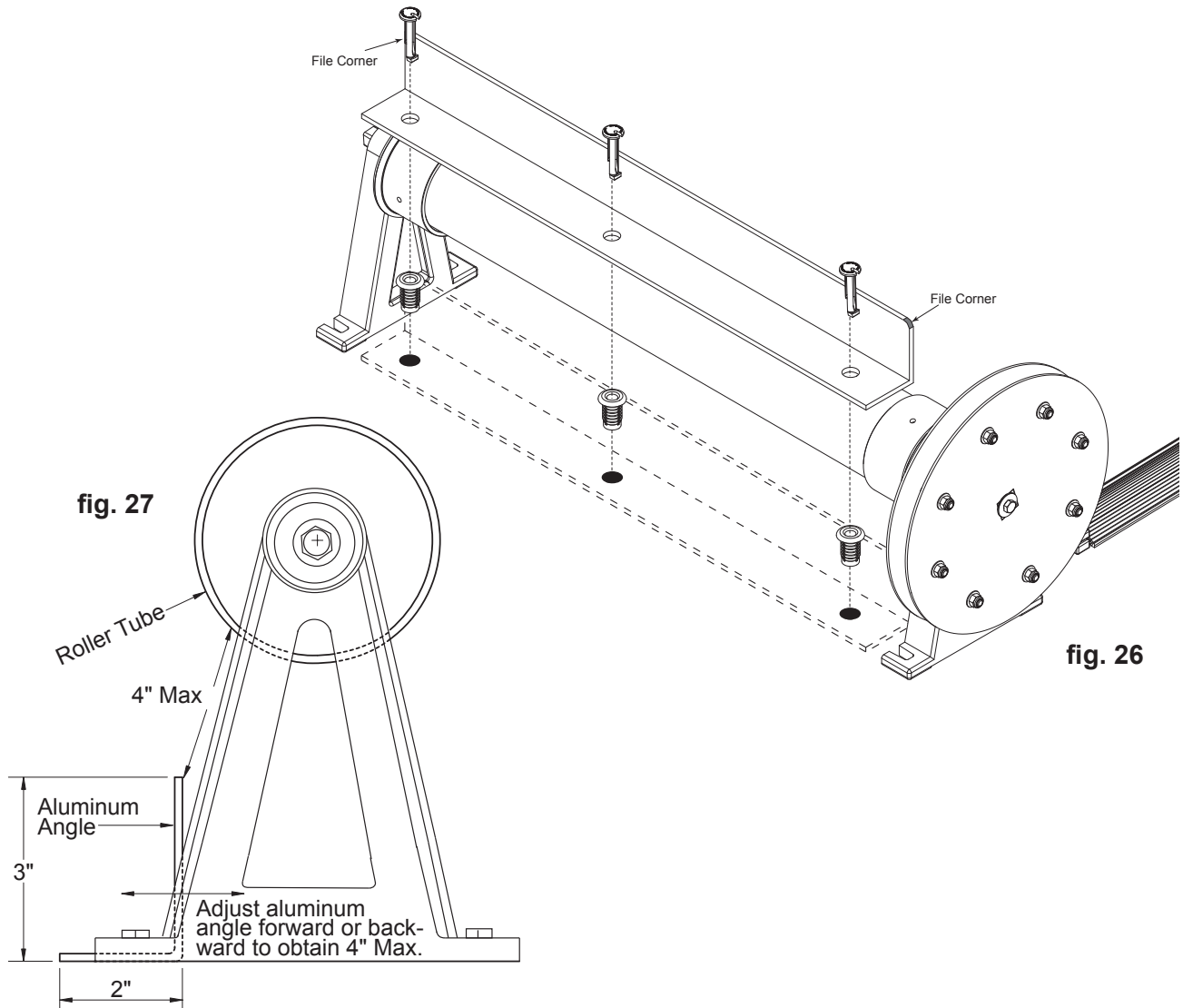

10. Optional Bonding

The National Electric Code requires all metal parts around a swimming pool to be bonded. Check the local code in your area to see if bonding is required. Bonding is achieved by connecting a #8 gauge solid copper wire from the pool bonding grid to the pool cover mechanism.

10.1 Connect the bonding lug to the leading edge. (fig. 28)

- 10.1.1 Connect the braided cable from the cover webbing to the bonding lug on the leading edge.
- 10.1.2 Leave enough slack in the bonding cable to allow for leading edge shifting.

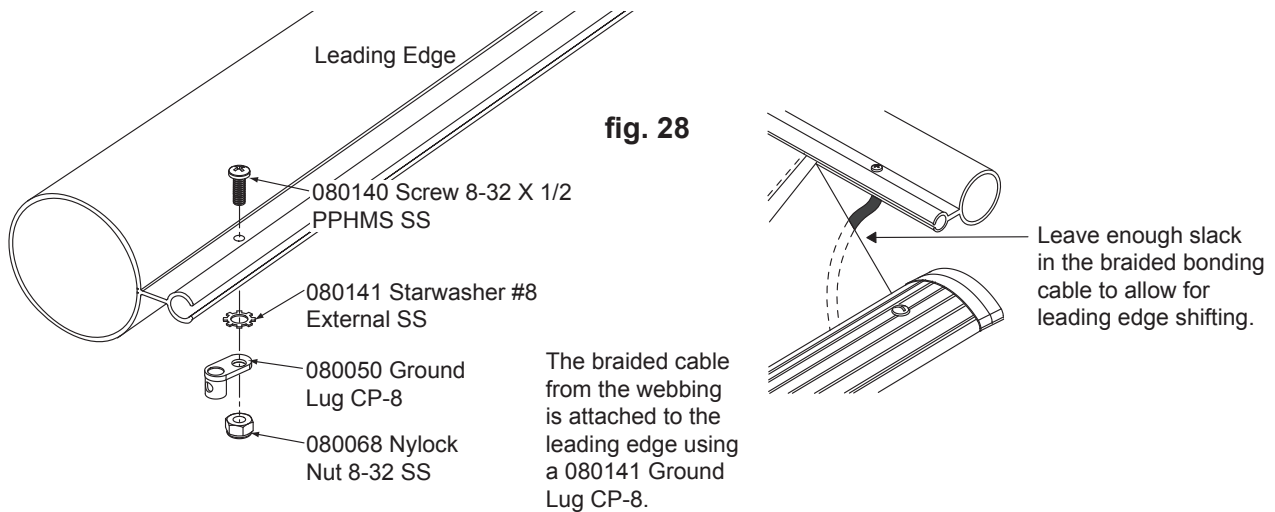

10.2 Connect the bonding lug to the A-frames. (fig. 29)

- 10.2.1 Connect #8 solid copper wires from the pool bonding grid to the ground lugs on the A-frames.

10.3 Replace the plastic bushing with the brass bushing. (fig. 30)

- 10.3.1 On the roller handle side, remove the paint from roller hubs and inside the hole of the A-frames for bushing conductivity.

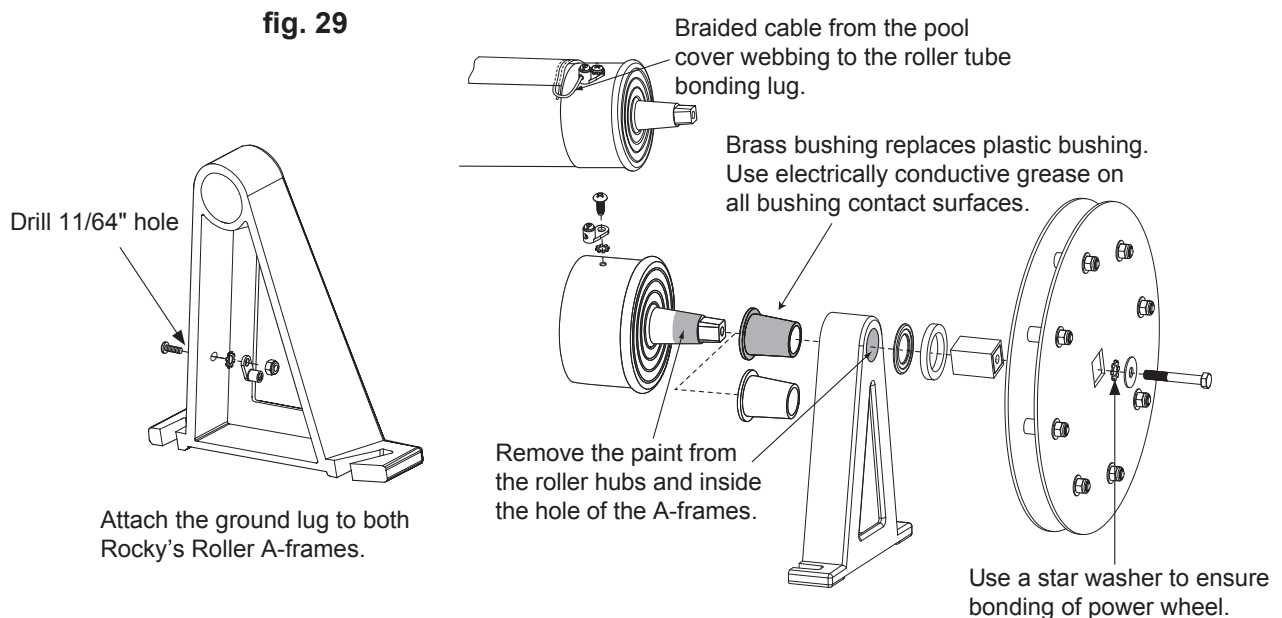

10.4 Connect the bonding lug to the aluminum angle. (fig. 30)

- 10.4.1 Connect a #8 solid copper wire from pool-bonding grid to the ground lug on the aluminum angle.

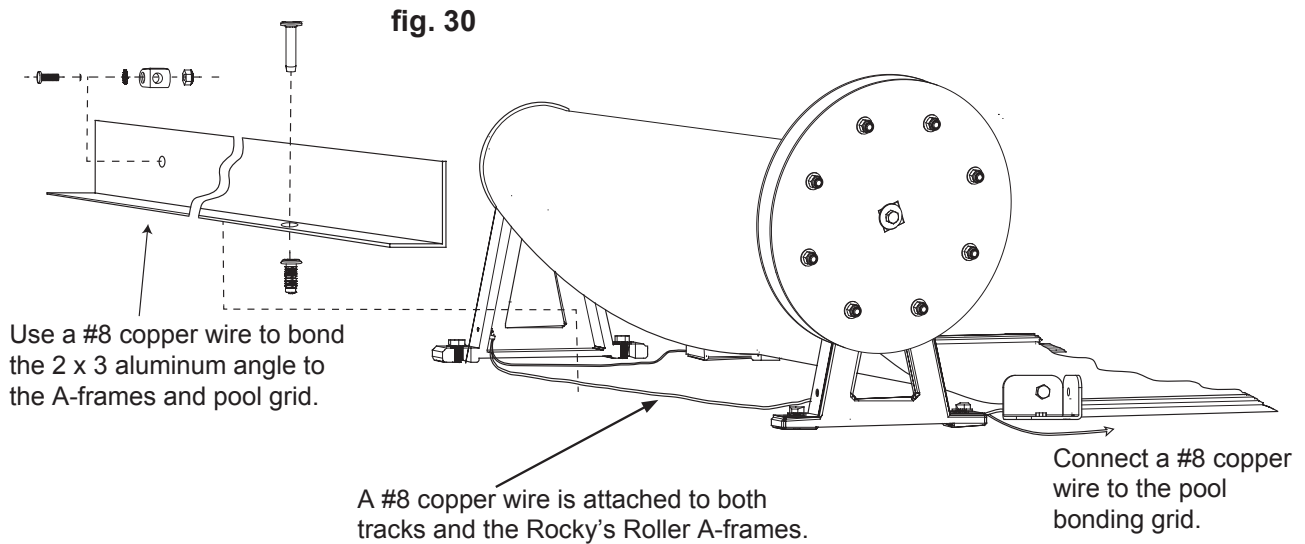

10.5 Connect the bonding lug to the track. (fig. 31)

- 10.5.1 Drill an 11/64" hole 3" from mechanism end of track.
- 10.5.2 Attach the bonding lug to the underside of the track.
- 10.5.3 Connect a #8 solid copper wire from the pool bonding grid to the bonding lug on the track. (See page 6 for bonding of Snap-Top Track)

